

ELECTRIC ACTUATOR

J3CS S20 & B20



GENERAL CHARACTERISTICS

Housing: Anticorrosive polyamide (lid & body)

Main external shaft: Anticorrosive polyamide

External screws: stainless steel

Gears: Steel and polyamide

Visual position indicator: Polyamide

Dome: Polycarbonate

Adjustable internal cams: Polyamide

Electric motor: Single phase 24VDC

Insulation: Class B

(IEC 60034) Service: S4



DATASHEET

Model	S20	B20
Voltage VDC/VAC 50/60Hz -0/+5%	24 a 240 (Patent Pending)	12 V ONLY
Operation time unload	10 Sec./90°	10 Sec./90°
Maximum torque break	25 Nm / 221 lb/in	25 Nm / 221 lb/in
Maximum operational torque	20 Nm / 177 lb/in	20 Nm / 177 lb/in
Duty rating	75 %	75 %
Max. Working angle	0° to 270°	0° to 270°
Limit switch	4 SPST NO micro (2 motor stop and 2 confirmations)	4 SPST NO micro (2 motor stop and 2 confirmations)
Automatic heater	3,5 W	3,5 W
Big Plug	EN175301-803 FORM A	EN175301-803 FORM A
Small Plug	DIN43650/C	DIN43650/C
Protection IEC 60529 rating	IP67	IP67
Temperature	-20°C +70°C / -4°F +158°F	-20°C +70°C / -4°F +158°F
Weight	1,8 Kg	1,8 Kg



VALVE CONNECTION

ISO 5211 Plate : F03/F04/F05

DIN 3337 Female output drive : *14 mm

Options:

DIN 3337 Female output drive: *9 or *11 mm

F05 to F07 Conversion Kit with *17mm output



OPTIONS

-J3CS 20/85 DPS 2017 digital positioner: 4-20mA, 0-20mA, 0-10V or 1-10V.

-J3CS 20/85 BSR 2017 emergency fail safe kit system by battery

-Digital potentiometer: 1K, 5K or 10K.

-3 position actuator: 0°-45°-90° or 0°-90°-180°

J3CS S20 & B20 SIZES

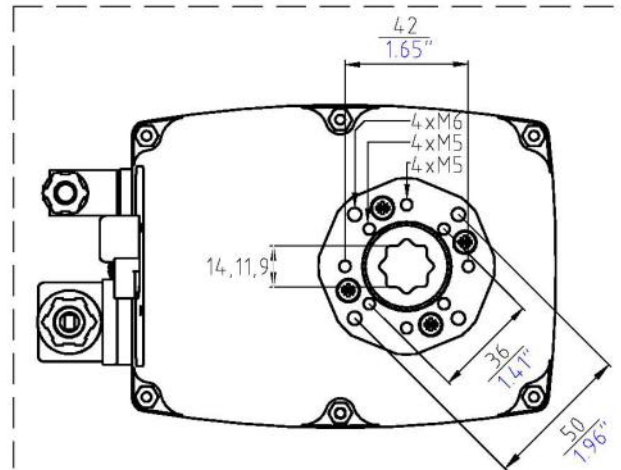
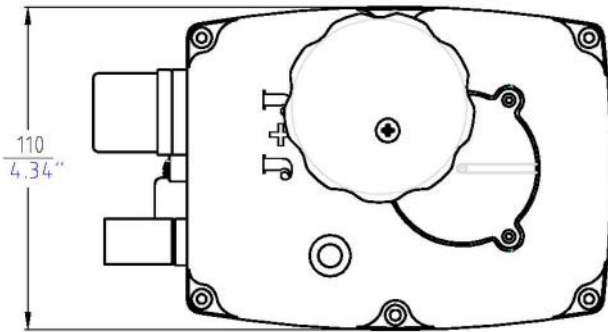
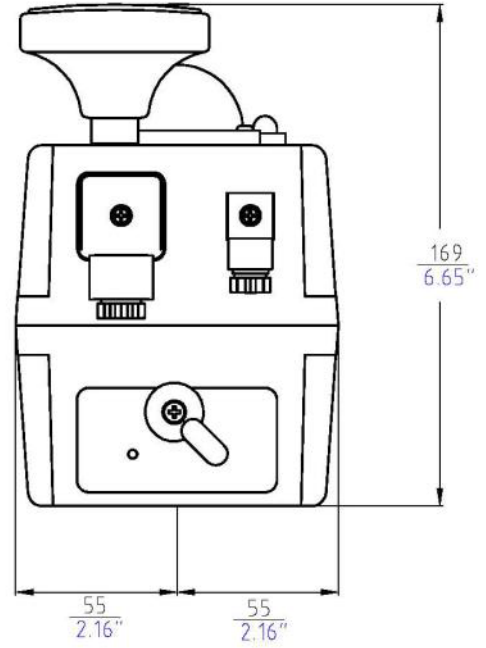
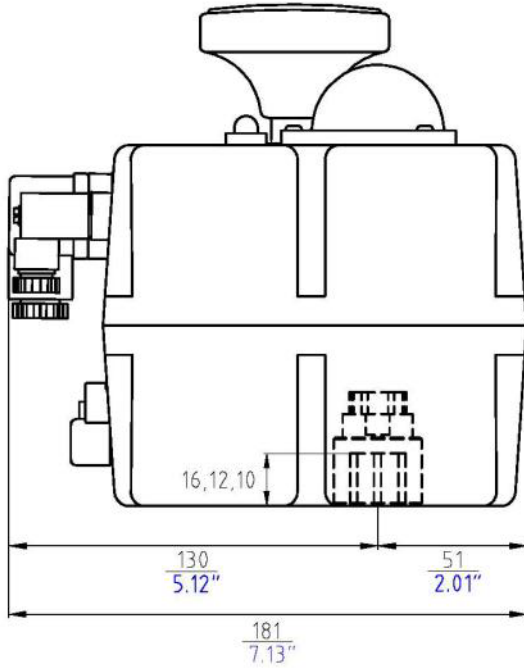

ELECTRIC ACTUATOR

J3CS S35 & B35



GENERAL CHARACTERISTICS

Housing: Anticorrosive polyamide (lid & body)

Main external shaft: stainless steel

External screws: stainless steel

Gears: Steel and polyamide

Visual position indicator: Polyamide

Dome: Polycarbonate

Adjustable internal cams: Polyamide

Electric motor: Single phase 24VDC

Insulation: Class B

(IEC 60034) Service: S4

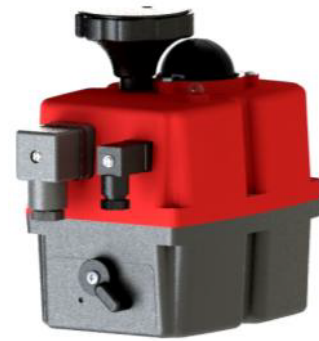

DATASHEET

Model	S35	B35
Voltage VDC/VAC 50/60Hz -0/+5%	24 a 240 (Patent Pending)	12 V ONLY
Operation time unload	10 Sec./90°	10 Sec./90°
Maximum torque break	38 Nm / 359.3 lb/in	38 Nm / 359.3 lb/in
Maximum operational torque	35 Nm / 309 lb/in	35 Nm / 309 lb/in
Duty rating	75 %	75 %
Max. Working angle	0° to 270°	0° to 270°
Limit switch	4 SPST NO micro (2 motor stop and 2 confirmation)	4 SPST NO micro (2 motor stop and 2 confirmation)
Automatic heater	3,5 W	3,5 W
Big Plug	EN175301-803 FORM A	EN175301-803 FORM A
Small Plug	DIN43650/C	DIN43650/C
Protection IEC 60529 rating	IP67	IP67
Temperature	-20°C +70°C / -4°F +158°F	-20°C +70°C / -4°F +158°F
Weight	1,9 Kg	1,9 Kg



VALVE CONNECTION

ISO 5211 Plate : F03/F04/F05

DIN 3337 Female output drive : *14 mm

Options:

DIN 3337 Female output drive: *9 or *11 mm

F05 to F07 Conversion Kit with *17mm output



OPTIONS

-J3CS 20/85 DPS 2017 digital positioner: 4-20mA, 0-20mA, 0-10V or 1-10V.

-J3CS 20/85 BSR 2017 emergency fail safe kit system by battery

-Digital potentiometer: 1K, 5K or 10K.

-3 position actuator: 0°-45°-90° or 0°-90°-180°

J3CS S35 & B35 SIZES

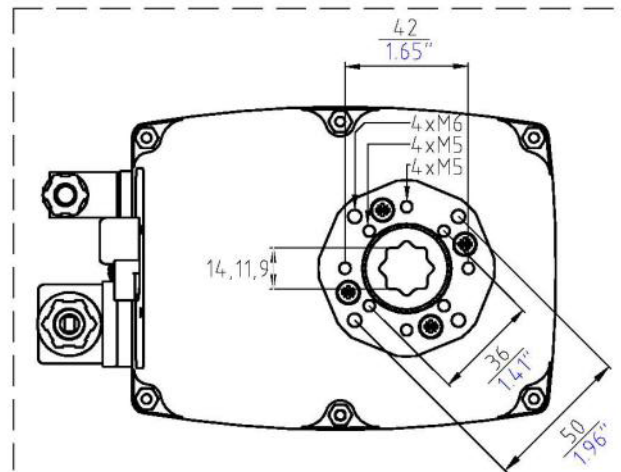
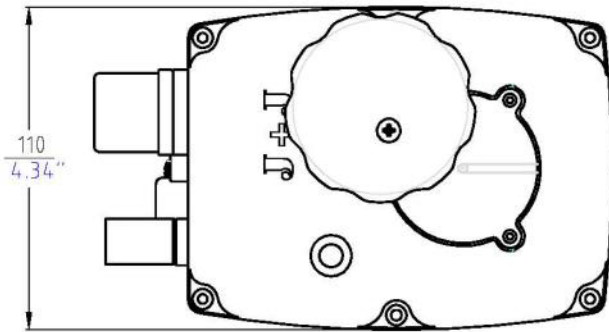
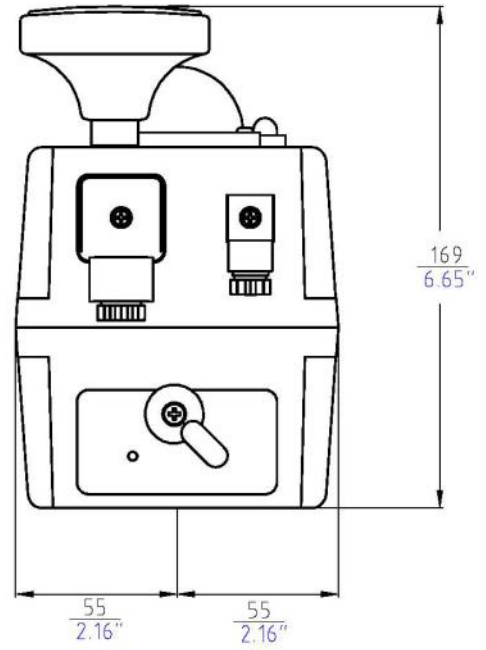
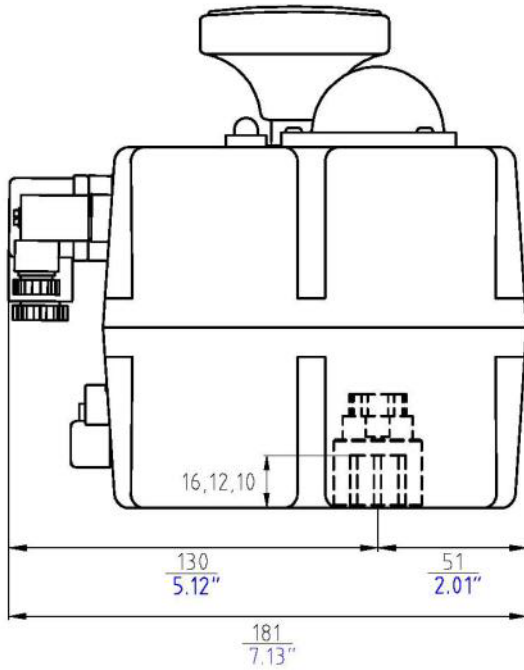

ELECTRIC ACTUATOR

J3CS S55 & B55



GENERAL CHARACTERISTICS

Housing: Anticorrosive polyamide (lid & body)

Main external shaft: stainless steel

External screws: stainless steel

Gears: Steel and polyamide

Visual position indicator: Polyamide

Dome: Polycarbonate

Adjustable internal cams: Polyamide

Electric motor: Single phase 24VDC

Insulation: Class B

(IEC 60034) Service: S4

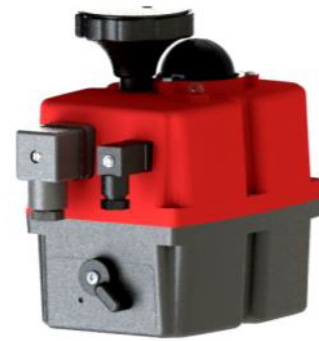

DATASHEET

Model	S55	B55
Voltage VDC/VAC 50/60Hz -0/+5%	24 a 240 (Patent Pending)	12 V ONLY
Operation time unload	14 Sec./90°	14 Sec./90°
Maximum torque break	60 Nm / 530 lb/in	60 Nm / 530 lb/in
Maximum operational torque	55 Nm / 486 lb/in	55 Nm / 486 lb/in
Duty rating	75 %	75 %
Max. Working angle	0° to 270°	0° to 270°
Limit switch	4 SPST NO micro (2 motor stop and 2 confirmations)	4 SPST NO micro (2 motor stop and 2 confirmations)
Automatic heater	3,5 W	3,5 W
Big Plug	EN175301-803 FORM A	EN175301-803 FORM A
Small Plug	DIN43650/C	DIN43650/C
Protection IEC 60529 rating	IP67	IP67
Temperature	-20°C +70°C / -4°F +158°F	-20°C +70°C / -4°F +158°F
Weight	2,4 Kg	2,4 Kg



VALVE CONNECTION

ISO 5211 Plate : F05/F07

DIN 3337 Female output drive : *17 mm

Option:

DIN 3337 Female output drive: *11 or *14 mm



OPTIONS

-J3CS 20/85 DPS 2017 digital positioner: 4-20mA, 0-20mA, 0-10V or 1-10V.

-J3CS 20/85 BSR 2017 emergency fail safe kit system by battery

-Digital potentiometer: 1K, 5K or 10K.

-3 position actuator: 0°-45°-90° or 0°-90°-180°

J3CS S55 & B55 SIZES

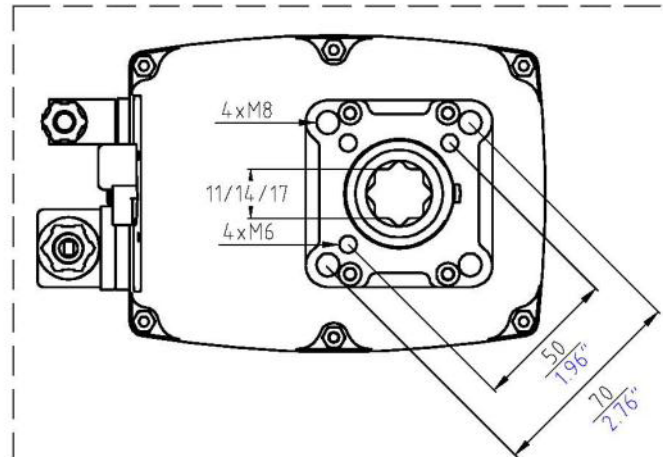
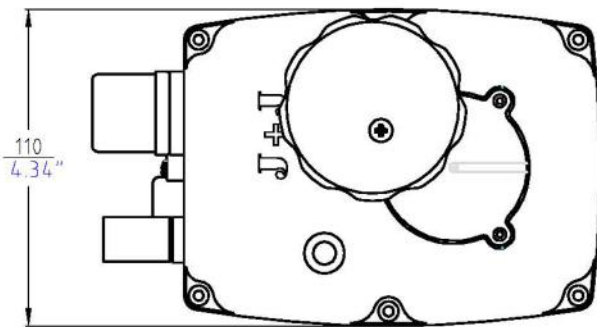
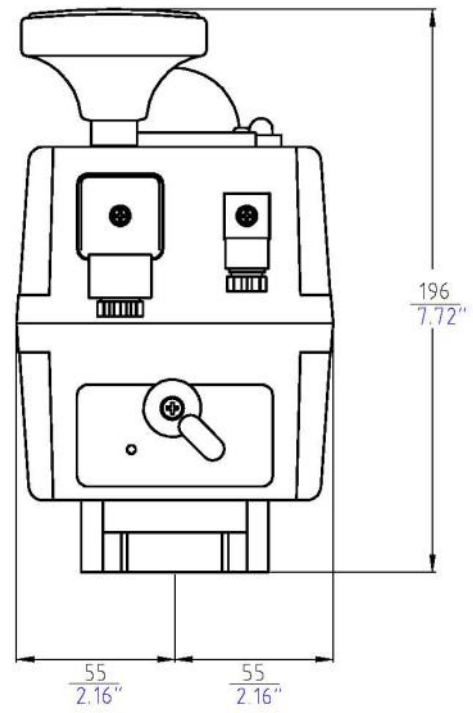
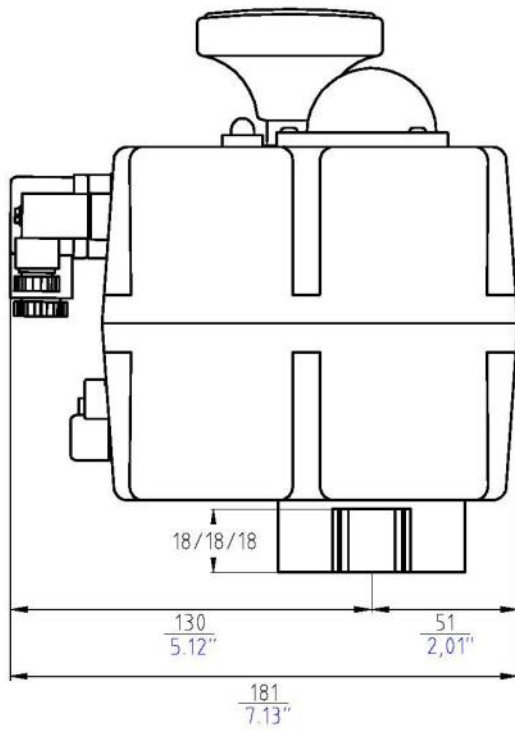

ELECTRIC ACTUATOR

J3CS S85& B85



GENERAL CHARACTERISTICS

Housing: Anticorrosive polyamide (lid & body)

Main external shaft: stainless steel

External screws: stainless steel

Gears: Steel and polyamide

Visual position indicator: Polyamide

Dome: Polycarbonate

Adjustable internal cams: Polyamide

Electric motor: Single phase 24VDC

Insulation: Class B

(IEC 60034) Service: S4



DATASHEET

Model	S85	B85
Voltage VDC/VAC 50/60Hz -0/+5%	24 a 240 (Patent Pending)	12 V ONLY
Operation time unload	30 Sec./90°	30 Sec./90°
Maximum torque break	90 Nm / 796,3 lb/in	90 Nm / 796,3 lb/in
Maximum operational torque	85 Nm / 752 lb/in	85 Nm / 752 lb/in
Duty rating	75 %	75 %
Max. Working angle	0° to 270°	0° to 270°
Limit switch	4 SPST NO micro (2 motor stop and 2 confirmations)	4 SPST NO micro (2 motor stop and 2 confirmations)
Automatic heater	3,5 W	3,5 W
Big Plug	EN175301-803 FORM A	EN175301-803 FORM A
Small Plug	DIN43650/C	DIN43650/C
Protection IEC 60529 rating	IP67	IP67
Temperature	-20°C +70°C / -4°F +158°F	-20°C +70°C / -4°F +158°F
Weight	3 Kg	3 Kg



VALVE CONNECTION

ISO 5211 Plate : F05/F07

DIN 3337 Female output drive : *17 mm

Option:

DIN 3337 Female output drive: *11 or *14 mm



OPTIONS

-J3CS 20/85 DPS 2017 digital positioner: 4-20mA, 0-20mA, 0-10V or 1-10V.

-J3CS 20/85 BSR 2017 emergency fail safe kit system by battery

-Digital potentiometer: 1K, 5K or 10K.

-3 position actuator: 0°-45°-90° or 0°-90°-180°

J3CS S85 & B85 SIZES

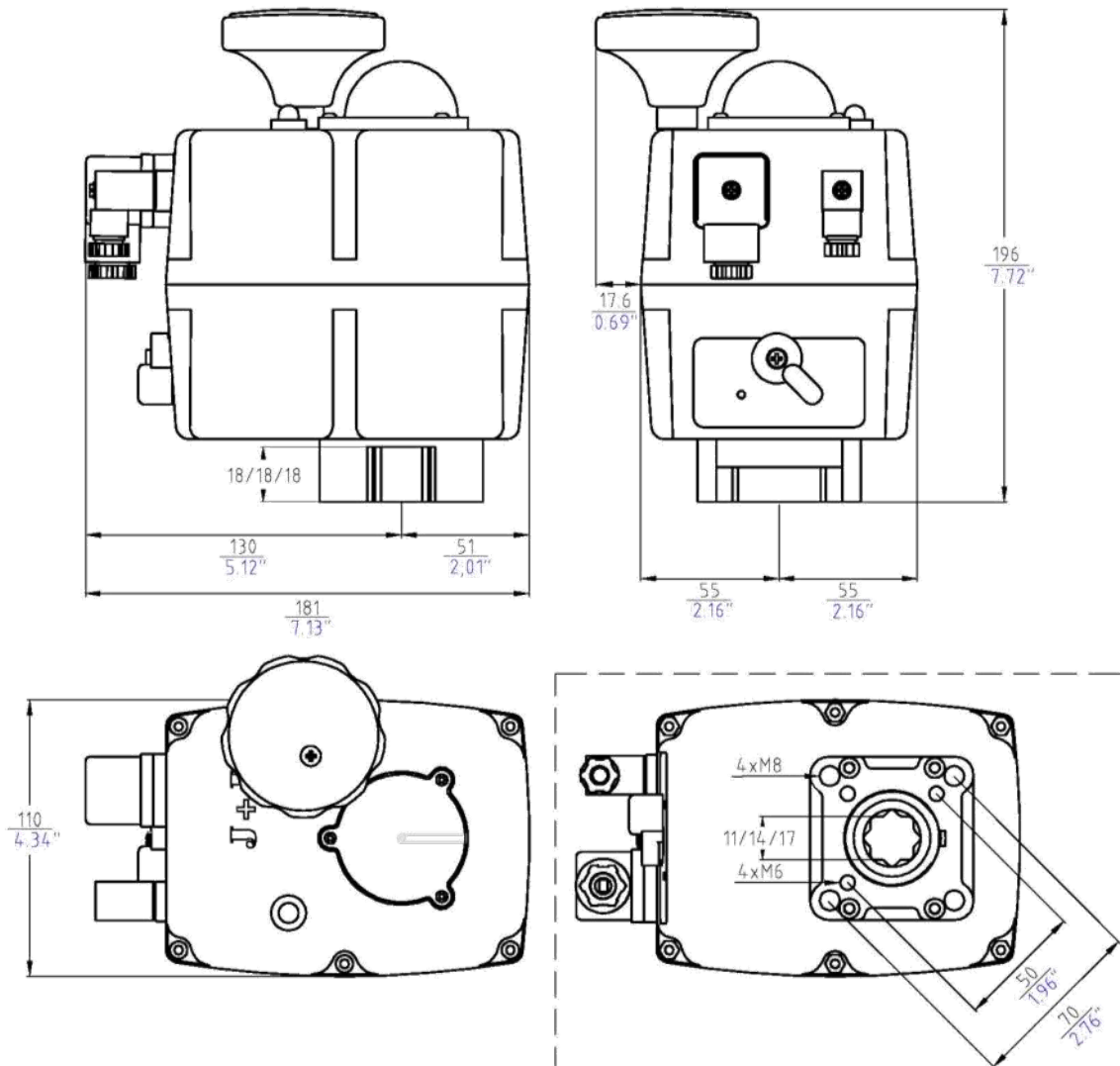

J3CS SERIES - MODEL S20, S35 , S55, S85, B20, B35, B55 & B85

"S" & "B" models - Novelties to be pointed out:

1-VISUAL CONTROL OF OPERATION:

Through the VISUAL CONTROL OF OPERATION one could see a different color LED light, fixed or blinking, from which, one could know what is the operation the actuator is making or which is the incidence the actuator is facing.

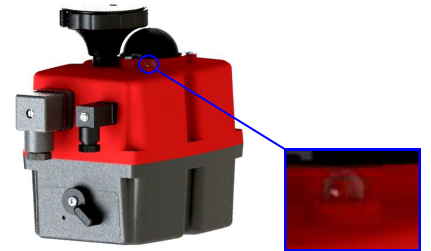

VISUAL CONTROL OF OPERATION

2- VOLTAGE TO BE CONNECTED

- All **S20 to S85** actuators have been set-up to work from **24-240 VDC/VAC (Patent pending)**.
- All **B20 to B85** actuators have been set-up to work at **12 VDC/VAC ONLY**.

3-ID ACTUATOR LABEL

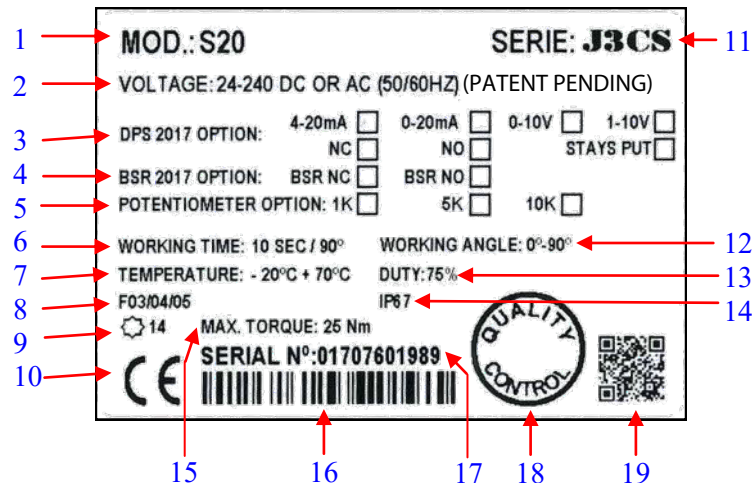

- 1-Actuator Model.
- 2-Voltage to be connected.
- 3-DPS 2017 options.
- 4-BSR 2017 options.
- 5-POTENTIOMETER options.
- 6-Time the actuator needs to run to the indicated degrees.
- 7-Actuator ready to bear between -20°C y $+70^{\circ}\text{C}$.
- 8-Plate to fix the valve to the actuator, following ISO 5211.
- 9-Female output drive size, following DIN3337.
- 10-Actuator with the CE certificate.
- 11-Actuator Series.
- 12-Working angle.
- 13-Duty: 75%.
Example: S20 Model - Maneuver time = 10sec. Time between maneuvers = 3.3 sec.
- 14-Actuator with the IP67 protection.
- 15-Maximum torque break.
- 16-Bar code of the serial number.
- 17-Actuator serial number.
- 18-Quality Control Conformity .
- 19-QR code for manufacturing.

4-BSR 2017 J3CS 20/85 KIT

For actuator models S20 to S85 and B20 to B85, there is a new BSR 2017 KIT, which drives the actuator to the OPEN (BSR NO) or to the CLOSE position (BSR NC) in case of a power supply failure, by using an internal battery system. Always depending on the previous set-up configuration.

5-DPS 2017 J3CS 20/85 KIT

For actuator models S20 to S85 and B20 to B85, there is a new DPS 2017 KIT, which allow us to put the actuator in any position throughout its working angle, by using a 4-20mA or a 0-10V signal. In case one would like to use a 0-20mA or a 1-10V signal, ask the distributor.

ACTUATOR PART LIST

MODELS: S20, S35, S55, S85, B20, B35, B55 & B85

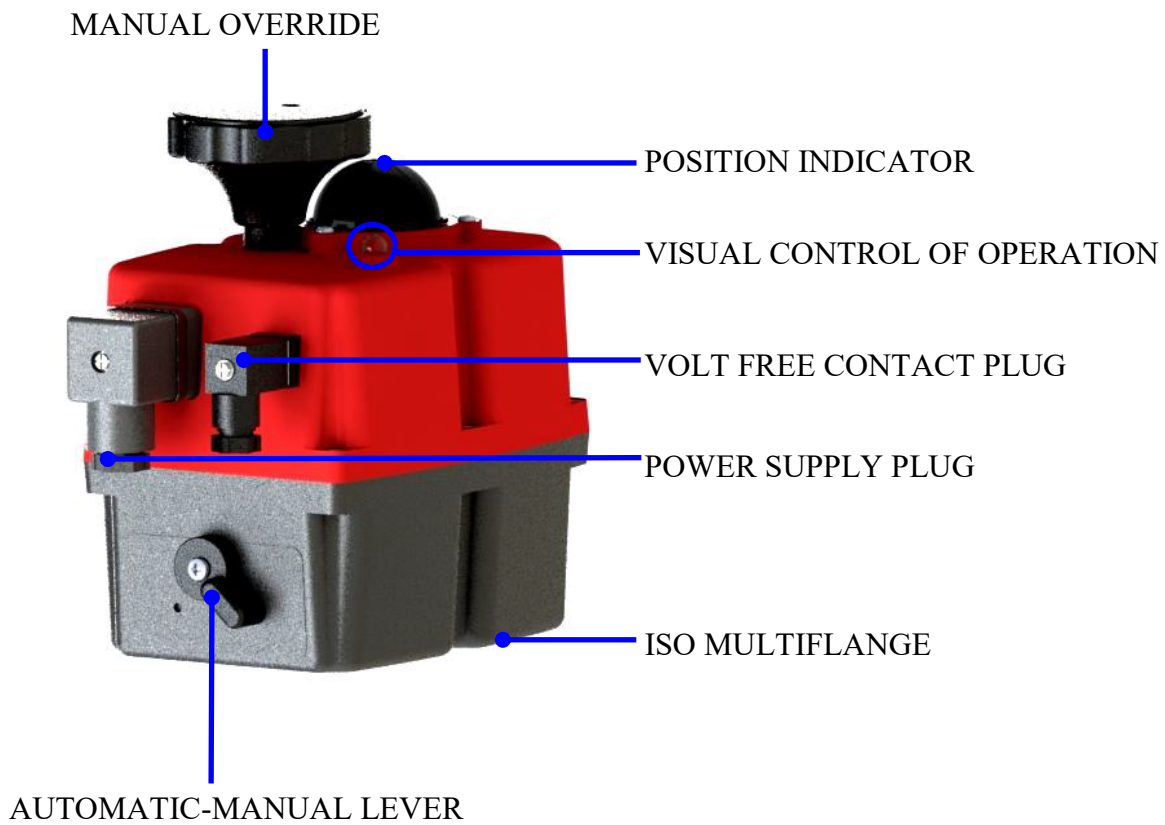

TABLE OF CONSUMPTIONS

J3CS 20 Consumption		Unload		Max. Operational Torque 20Nm		Max. Torque Break 25Nm	
Voltage	Model	A	W	A	W	A	W
12 VDC	B20	0,75	9,06	1,80	21,60	1,95	23,36
24 VDC	S20	0,45	10,77	0,90	21,49	0,97	23,39
48 VDC	S20	0,21	9,93	0,42	20,38	0,46	22,07
12 VAC	B20	1,04	12,51	1,85	22,18	2,28	27,32
24 VAC	S20	0,59	14,20	1,12	26,77	1,28	30,62
48 VAC	S20	0,34	16,37	0,69	33,16	0,75	36,22
110 VAC	S20	0,14	15,73	0,27	29,52	0,30	32,67
240 VAC	S20	0,10	23,76	0,15	36,43	0,16	39,07

J3CS 35 Consumption		Unload		Max. Operational Torque 35Nm		Max. Torque Break 38Nm	
Voltage	Model	A	W	A	W	A	W
12 VDC	B20	0,75	9,06	2,38	28,62	2,62	31,50
24 VDC	S20	0,45	10,77	1,28	30,78	1,37	32,79
48 VDC	S20	0,21	9,93	0,56	26,72	0,59	28,20
12 VAC	B20	1,04	12,51	2,75	33,00	3,19	38,28
24 VAC	S20	0,59	14,20	1,58	37,80	1,67	40,13
48 VAC	S20	0,34	16,37	0,92	44,04	0,99	47,31
110 VAC	S20	0,14	15,73	0,36	39,45	0,38	41,87
240 VAC	S20	0,10	23,76	0,19	45,41	0,20	47,52

J3CS 55 Consumption		Unload		Max. Operational Torque 55Nm		Max. Torque Break 60Nm	
Voltage	Model	A	W	A	W	A	W
12 VDC	B20	0,70	8,45	3,04	36,43	3,42	41,05
24 VDC	S20	0,42	10,19	1,55	37,17	1,63	39,02
48 VDC	S20	0,20	9,72	0,61	29,25	0,67	32,31
12 VAC	B20	0,94	11,30	3,43	41,18	3,78	45,41
24 VAC	S20	0,58	13,89	1,87	44,88	1,98	47,52
48 VAC	S20	0,33	15,73	1,10	52,80	1,21	58,29
110 VAC	S20	0,14	15,73	0,40	43,80	0,43	46,95
240 VAC	S20	0,09	22,70	0,20	47,52	0,21	50,16

J3CS 85 Consumption		Unload		Max. Operational Torque -85Nm		Max. Torque Break -90Nm	
Voltage	Model	A	W	A	W	A	W
12 VDC	B20	0,62	7,42	2,11	25,34	2,28	27,32
24 VDC	S20	0,36	8,55	1,08	25,87	1,22	29,30
48 VDC	S20	0,17	8,24	0,48	22,92	0,53	25,56
12 VAC	B20	0,81	9,69	2,38	28,51	2,65	31,81
24 VAC	S20	0,50	11,88	1,36	32,74	1,50	36,01
48 VAC	S20	0,25	11,83	0,77	37,07	0,86	41,18
110 VAC	S20	0,12	12,83	0,31	33,64	0,33	36,54
240 VAC	S20	0,08	20,06	0,17	40,13	0,18	42,77

EXTERNAL CONNECTING DIAGRAM

3 WIRES ON - OFF

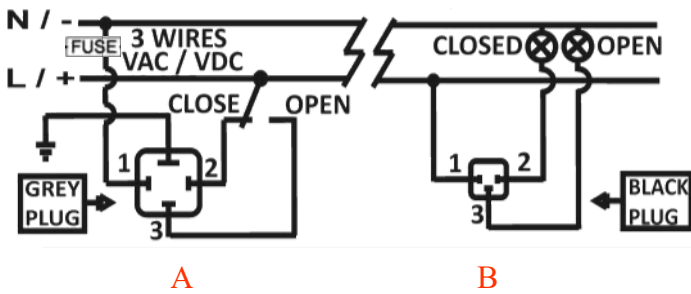

- A = Power supply plug
- A: VAC 3 WIRES (Grey plug)
 - PIN 1 = Neutral + PIN 2 = Phase = Close
 - PIN 1 = Neutral + PIN 3 = Phase = Open
- A: VDC 3 WIRES (Grey plug)
 - PIN 1 = (-) Negative + PIN 2 = (+) Positive = Close
 - PIN 1 = (-) Negative + PIN 3 = (+) Positive = Open
- B = Volt free contact, plug
 - PIN 1 / PIN 2 = Close
 - PIN 1 / PIN 3 = Open

2 WIRES ON - OFF

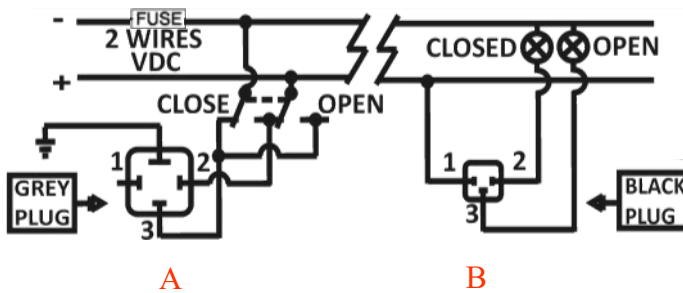

- A = Power supply plug
- A: VDC 2 WIRES (Grey plug)
 - PIN 2 = (+) Positive + PIN 3 = (-) Negative = Close
 - PIN 2 = (-) Negative + PIN 3 = (+) Positive = Open
- B = Volt free contact plug
 - PIN 1 / PIN 2 = Close
 - PIN 1 / PIN 3 = Open

POSITIONER

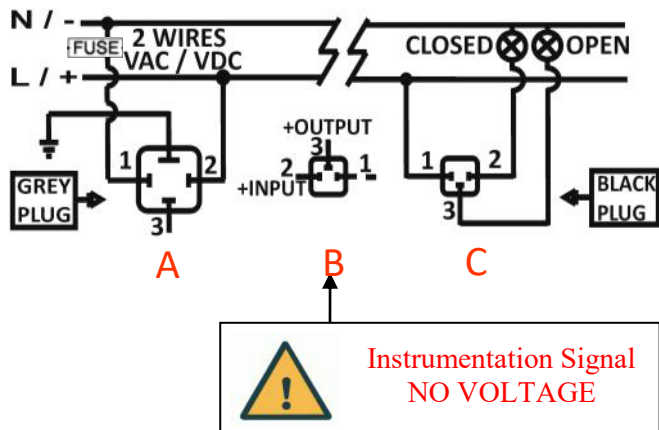

- A = Power supply plug
- A: VAC 2 WIRES (Grey plug)
 - PIN 1 = Neutral + PIN 2 = Phase = Power supply plug
- A: VDC 2 WIRES (Grey plug)
 - PIN 1 = (-) Negative + PIN 2 = (+) Positive = Power supply plug
- B = Instrumentation Signal
 - B: Input signal : 4/20mA or 0/10V
 - PIN 1 = (-) Negative + PIN 2 = (+) Positive = Input signal
 - PIN 1 = (-) Negative + PIN 3 = (+) Positive = Output signal
- C = Volt free contact plug
 - PIN 1 / PIN 2 = Closed
 - PIN 1 / PIN 3 = Open

ACTUATOR OPERATIONAL STATUS

MODELS: S20, S35, S55, S85, B20, B35, B55 & B85

The LED Light provides visual communication between the actuator and the user.
The current operational status is shown by different LED colors.

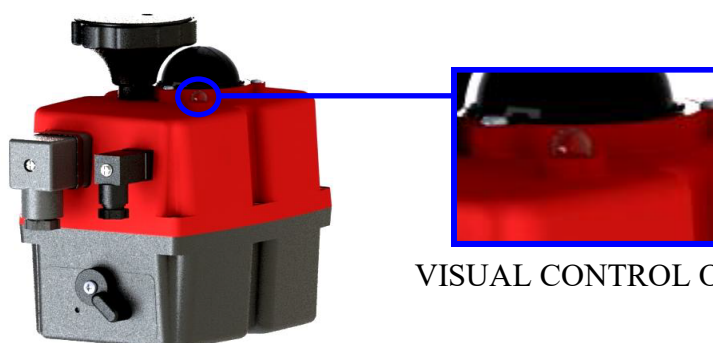

VISUAL CONTROL OF OPERATION

ON-OFF ACTUATOR	ACTUATOR OPERATIONAL STATUS											
Without power supply												
In open position												
In close position												
Opening												
Closing												
Torque limiter function on, moving from close to open												
Torque limiter function on, moving from open to close												
Actuator in MANUAL mode (Exceeded time)												
The actuator has stopped (no close/no open position)												
In middle position												
ACTUATOR WITH BSR 2017	ACTUATOR OPERATIONAL STATUS											
Without power supply												
In open position												
In close position												
Opening												
Closing												
Torque limiter function on, moving from close to open												
Torque limiter function on, moving from open to close												
Actuator in MANUAL mode (Exceeded time)												
The actuator has stopped (no close/no open position)												
In middle position												
Actuator without power, working with the BSR NO system. Max.3 min., (led off)												
Actuator without power, working with the BSR NC system. Max.3 min., (led off)												
Battery protection. Danger, the battery needs recharging. BSR blocked												

ACTUATOR WITH DPS 2017	ACTUATOR OPERATIONAL STATUS															
Without power supplied																
Motor stop																
Opening																
Closing																
Self adjusting configuration																
Torque limiter function on, moving from close to open																
Torque limiter function on, moving from open to close																
Instrum. Signal overpassed. Blocked actuator. Need a re-set.																
Actuator in MANUAL mode (exceeded time)																
No Instrum. Signal pick-up. 4-20mA and 1-10V only.																

DPS 2017 J 3 C S 20/85

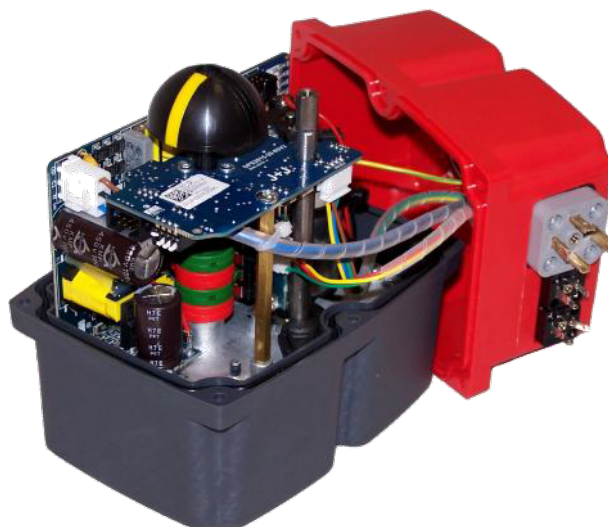

ESPECIFICACIONES / SPECIFICATIONS

MODELO / MODEL	S20-B20	S35-B35	S55-B55	S85-B85
Precisión Accuracy	3 % F.S.	3 % F.S.	3 % F.S.	3 % F.S.
Linealidad Linearity	2 % F.S.	2 % F.S.	2 % F.S.	2 % F.S.
Histéresis Hysteresis	3 % F.S.	3 % F.S.	3 % F.S.	3 % F.S.
Impulsos a 4/20mA Steps at 4/20mA	Min.142 steps 90°	Min.142 steps 90°	Min.142 steps 90°	Min.142 steps 90°
Impulsos a 0/10V Steps at 0/10V	Min.88 steps 90°	Min.88 steps 90°	Min.88 steps 90°	Min.88 steps 90°
Impulsos a 0/20mA Steps at 0/20mA	Min.166 steps 90°	Min.166 steps 90°	Min.166 steps 90°	Min.166 steps 90°
Impulsos 1/10V Steps at 1/10V	Min.85 steps 90°	Min.85 steps 90°	Min.85 steps 90°	Min.85 steps 90°
Impedancia señal entrada 4/20mA o 0/20mA 4/20mA or 0/20mA Input signal impedance	100 Ohm	100 Ohm	100 Ohm	100 Ohm
Impedancia señal entrada 0/10V o 1/10V 0/10V or 1/10V Input signal impedance	25 KOhm	25 KOhm	25 KOhm	25 KOhm
CLASE / CLASS	B+C to E DIN EN 15714 Inching + Modulation			
PESO / WEIGHT	0,600 Kg	0,600 Kg	0,600 Kg	0,600 Kg

F.S. Se refiere a todo el rango de medición
F.S. **Full Scale**

DPS 2017 J 3 C S 20/85

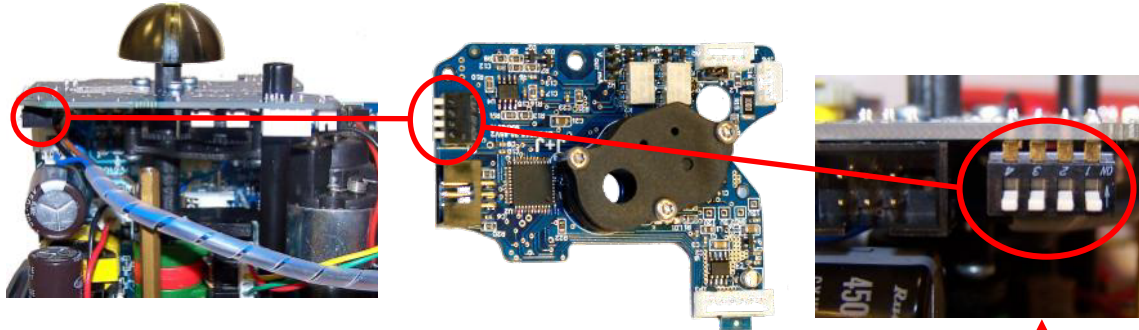

Aplicar la configuración necesaria para cada aplicación:
Posibles configuraciones:

Use the configuration you need by moving the DIPs:
Different possibilities of configuration:

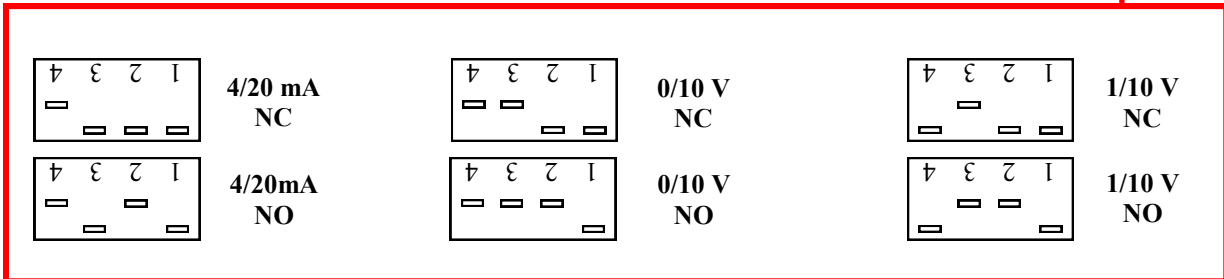

OTRAS OPCIONES A CONFIGURAR EN FABRICA O CON INTERFACE J3CS OTHER OPTIONS TO BE SET-UP BY THE MANUFACTURER OR WITH A J3CS INTERFACE	
SOLO SALIDA / OUTPUT ONLY	4/20 mA, 0/10 V, 0/20 mA, 1/10 V
ENTRADA Y SALIDA / INPUT & OUTPUT	0/20 mA
PARO MOTOR, A FALTA DE INSTRUMENTACIÓN / MOTOR STOP, WITHOUT INSTRUMENTATION	4/20 mA, 0/10 V, 0/20 mA, 1/10 V

BSR 2017 J 3 C S 20/85

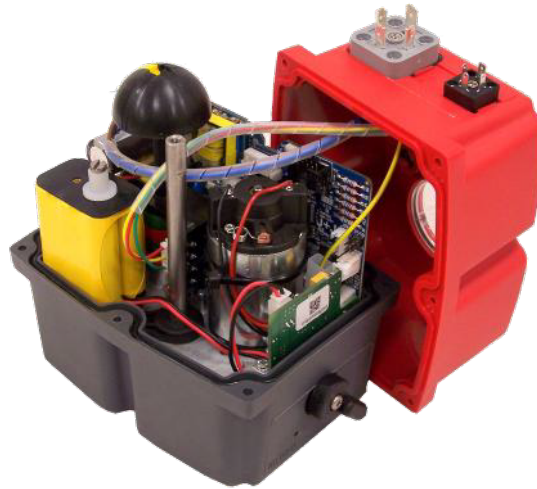

J3CS-20



J3CS-35



J3CS-55



J3CS-85

ESPECIFICACIONES / SPECIFICATIONS

MODELO ACTUADOR / ACTUATOR MODEL	S20-B20	S35-B35	S55-B55	S85-B85
Nº de Maniobras sin recargar, con batería 100% de carga Nº Working operation without recharge, with 100% battery charge	5	5	5	5
Tiempo de recarga/ maniobra. Recharge time/working operation	15 min	21 min	48 min	58 min
Consumo de batería/maniobra. Battery consumption/working operation	2,2 W	3,0 W	6,8 W	8,3 W
Tiempo de carga completa 100% Full charge time 100%	28 h	28 h	28 h	28 h
Capacidad nominal +/- 5% Nominal capacity +/- 5%	1000 mA	1000 mA	1000 mA	1000 mA
Configuración NA o NC (*) NO or NC Features (*)	Jumper	Jumper	Jumper	Jumper
Consumo/una maniobra con batería Current/one working operation with battery	10,1 mA	14 mA	31,6 mA	38.6 mA
Carga batería Battery charge	40 mA/h	40 mA/h	40 mA/h	40 mA/h
Peso Weight	0,27 Kg	0,27 Kg	0,27 Kg	0,27 Kg

CONFIGURACIONES / CONFIGURATIONS	A	B
POSICION PREFERENTE A FALLO DE CORRIENTE PREFERRED POSITION IN CASE OF POWER CUT	(NC) NORMALMENTE CERRADA (NC) NORMALLY CLOSE	(NO) NORMALMENTE ABIERTA (NO) NORMALLY OPEN

(*)

Configuración NA o NC / **NO or NC Set-Up**



Jumper 1
SELDIR

Configuración NC / **NC Set-Up**

NC - Si deseamos que el actuador, a fallo de corriente CIERRE, es necesario insertar el **jumper 1** en la posición SELDIR.

NC - If, in case of a power supply failure, we need the actuator go to the CLOSE position, we need to put the **jumper 1** on the SELDIR position.

Configuración NA / **NO Set-Up**

NO - Si deseamos que el actuador, a fallo de corriente ABRA, comprobar que en la posición SELDIR, no tenga el **jumper 1** montado.

NO - If, in case of a power supply failure, we need the actuator go to the OPEN position, be sure that the **jumper 1** is not on the SELDIR position.

OPCIONES CONEXIONES EXTERNAS / EXTERNAL ELECTRIC WIRING OPTIONS

(3 CABLES) / (3 WIRES)

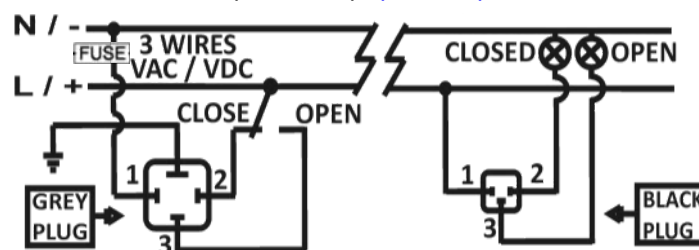

(2 CABLES) / (2 WIRES)

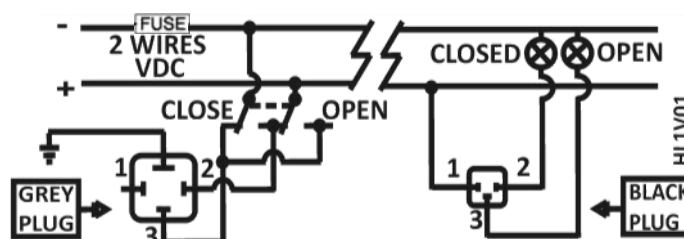

KIT DPS 2017 J 3 C S 20/85



OUTSIDE BOX



INSIDE BOX

El **DPS 2017** es un accesorio para los actuadores eléctricos J3CS que los convierte en posicionador de válvulas servo controladas.

El **DPS 2017** es un módulo que incorpora un microprocesador (CPU) el cual controla digitalmente la entrada y salida de señal analógica y compara ambas con la posición del actuador a fin de establecer una relación uniforme.

Las entradas analógicas son enviadas a la CPU donde son procesadas en continua comparación con la posición del actuador lo cual permite obtener un muy alto grado de sensibilidad y una muy alta repetitividad de posición (ver características).

El posicionador **DPS 2017**, en comunicación con el sistema electrónico del actuador, provee un control integral del movimiento del actuador.

The **DPS 2017** is a device for the J3CS electric actuator that turns the actuator into a servo controlled valve positioner.

The **DPS 2017** is a modulus with a microprocessor (CPU) which digitally manages the analogical input and output and compare them with the position of the actuator to establish a uniform relation.

The analogical inputs are sent to the CPU where they are processed for his continuous comparison with the position of the actuator, this allows to obtain a very high sensitivity next to a very high repetitivity of the position (see characteristics).

The **DPS 2017** in communication with the electronic system of the actuator provides an integral management of the motion of the actuator.

KIT DPS 2017 J 3CS 20/85



OUTSIDE BOX



INSIDE BOX

ESPECIFICACIONES / SPECIFICATIONS

MODELO / MODEL	S20-B20	S35-B35	S55-B55	S85-B85
Precisión Accuracy	3 % F.S.	3 % F.S.	3 % F.S.	3 % F.S.
Linealidad Linearity	2 % F.S.	2 % F.S.	2 % F.S.	2 % F.S.
Histéresis Hysteresis	3 % F.S.	3 % F.S.	3 % F.S.	3 % F.S.
Impulsos a 4/20mA Steps at 4/20mA	Min.142 steps 90°	Min.142 steps 90°	Min.142 steps 90°	Min.142 steps 90°
Impulsos a 0/10V Steps at 0/10V	Min.88 steps 90°	Min.88 steps 90°	Min.88 steps 90°	Min.88 steps 90°
Impulsos a 0/20mA Steps at 0/20mA	Min.166 steps 90°	Min.166 steps 90°	Min.166 steps 90°	Min.166 steps 90°
Impulsos 1/10V Steps at 1/10V	Min.85 steps 90°	Min.85 steps 90°	Min.85 steps 90°	Min.85 steps 90°
Impedancia señal entrada 4/20mA o 0/20mA 4/20mA or 0/20mA Input signal impedance	100 Ohm	100 Ohm	100 Ohm	100 Ohm
Impedancia señal entrada 0/10V o 1/10V 0/10V or 1/10V Input signal impedance	25 KOhm	25 KOhm	25 KOhm	25 KOhm
CLASE / CLASS	B+C to E DIN EN 15714 Inching + Modulation			
PESO / WEIGHT	0,600 Kg	0,600 Kg	0,600 Kg	0,600 Kg

F.S. Se refiere a todo el rango de medición
F.S. **Full Scale**

PIECES

- 1- 1 Cover
- 2- 1 4-pin grey power DIN plug
- 3- 2 4-pin small black DIN plug
- 4- 1 Rubber join for the big grey DIN plug
- 5- 2 Rubber join for the small black DIN plug
- 6- 1 Fixing screw for the grey DIN plug
- 7- 1 Fixing screw for the black DIN plug
- 8- 1 Hexagonal column
- 9- 1 DPS 2017 positioner PCB
- 10- 1 Plastic clamp
- 11- 1 DIN 7985 M4X8 screw
- 12- 2 O-ring
- 13- 1 Cover cap
- 14- 1 Plastic clip

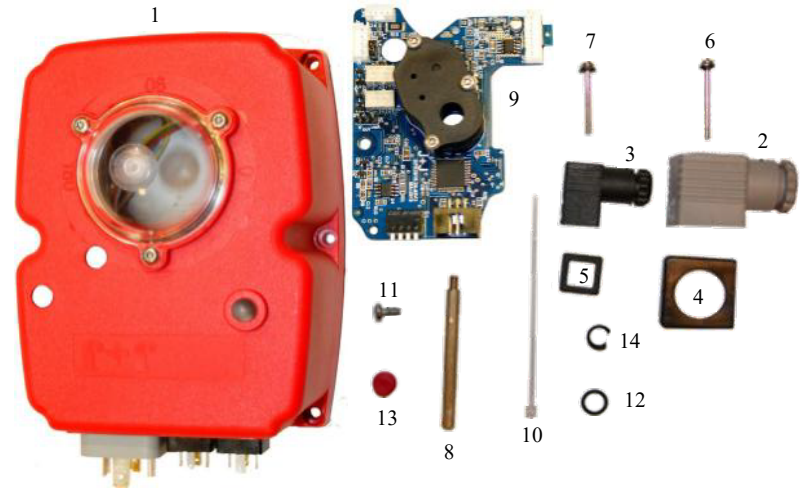
**PLEASE READ CAREFULLY BEFORE MOUNTING.**

VERY IMPORTANT!!!! PLEASE FOLLOW THE INSTRUCTIONS STEP BY STEP. BEFORE CONNECTING "A" PLUG TO THE ACTUATOR, CHECK THAT THE VOLTAGE IS THE SAME AS THE ONE SPECIFIED ON THE LABEL (CARTER).

PREPARING THE COVER:

J3CS-20, 35 & 55 model: Insert the o-ring (12) and the cover cap (13) inside hole n°1. Press until they are fully inside (Fig.1).

Insert the o-ring (12) and the Plastic clip (14) inside hole n°2. Press until they are fully inside (Fig.2).

J3CS-85 model: Insert the o-ring (12) and the cover cap (13) inside hole n°2. Press until they are fully inside (Fig.1).

Insert the o-ring (12) and the Plastic clip (14) inside hole n°1. Press until they are fully inside (Fig.2).

TO CONVERT A STANDARD (ON-OFF) J3CS ELECTRIC ACTUATOR INTO A MODULATING FUNCTION WITH POSITIONER, PROCEED AS FOLLOWS:

The unit must be disconnected from any electrical power or signal before installing.

1. Remove the screw from the cover of the hand wheel and take the cover off (Fig.3).
2. Do the same with the screw which is fixing the hand wheel. Take the hand wheel off. (Fig.4).
3. Remove the 6 screws, which are fixing the body to the cover of the actuator (Fig.5).
4. Carefully lift the cover and remove the cables connected to the actuator PCB (Fig.6).
5. Carefully remove the position indicator (Fig.7).
6. Remove the screw from the base plate (Fig.8).
7. Fix the hexagonal column (8) on the base plate (Fig.9).
8. Take the DPS 2017 cover and connect the 3 pin power supply plug to its connector base (1) on the actuator PCB (Fig.10). Connect the 5 pin confirmation plug into its connector base on the actuator PCB (2) (Fig.10). Then connect the earth connector (yellow/green) cable into its connector base (3) (Fig.10).
9. Mount the DPS2017 positioner PCB (9), matching the cleft of the shaft with the key inside the DPS 2017 gear (Fig.11). Be sure that the Power Supply cable remains as per in the picture (Fig. 12). Press the DPS2017 positioner PCB (9) along the shaft until the PCB connector (JP3) is plugged in the actuator PCB connector (JP2) (Fig.13).
10. Fix the DPS2017 positioner PCB (9) to the hexagonal column (8) with the screw (11) (Fig.14).
11. Connect the 4 pin control signal plug (DPS 2017 cover) into the corresponding connector base (4) on the DPS 2017 PCB (Fig.15).
12. Fix the (blue, black and brown) cables by a plastic clamp (10) to the hexagonal column (8) (Fig.16). Cut down the remaining piece of clamp.
13. Carefully insert the position indicator, matching its inner key with the cleft of the shaft (Fig.17).
14. In order to set the actuator up, use the DIPs shown in picture (Fig.18).
Put DIP 1 in ON position, connect the grey connector to the power supply, put DIP 1 back to the prior position. Wait until the actuator make a complete maneuver.
15. Use the configuration you need by moving the DIPs:

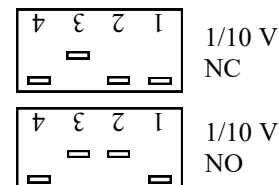
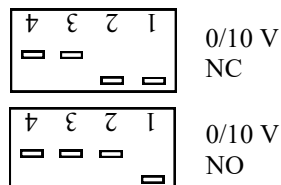
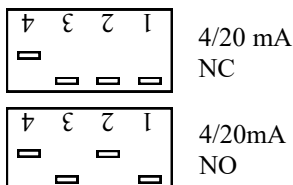

16. Disconnect the grey connector from the power supply.
17. Carefully mount the cover, minding the cables not to be pressed (Fig.19).
18. Fix the cover to the body by using the 6 screws (Fig.20).
19. Mount the hand wheel on the shaft and fix it by using the screw (Fig.21).
20. Put the cover on the hand wheel and fix it by using the screw (Fig. 22).
21. Mount the 3 connectors (2&3) together with its rubber joints (4&5) and fix them to the cover, by using the screws (6&7) (Fig.23).
The unit is ready to work.

Outer Set-Up: Only if necessary.

- B plug - Connect a cable between PIN 1 and PIN Earth (Fig. 24).
 - A plug - Connect it to the power supply.
 - B plug, disconnect the cable between PIN 1 and PIN Earth.
- The actuator will make a complete maneuver.
Connect B connector to the actuator. The actuator is ready to work.

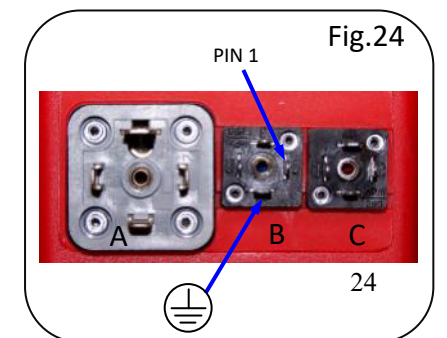
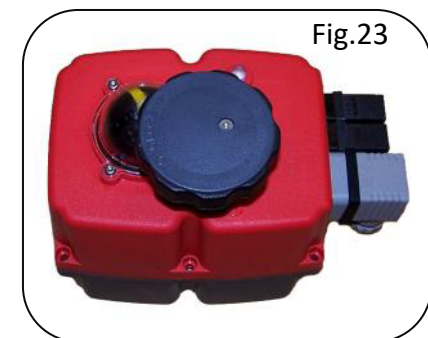
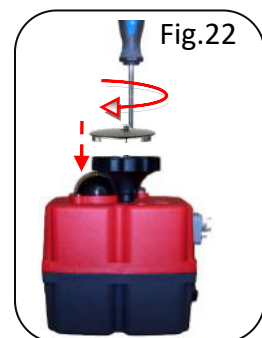
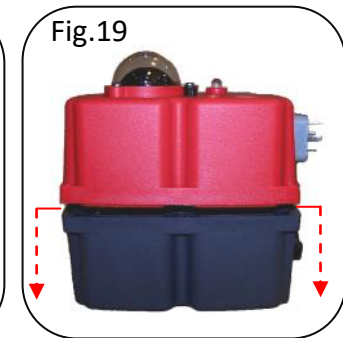
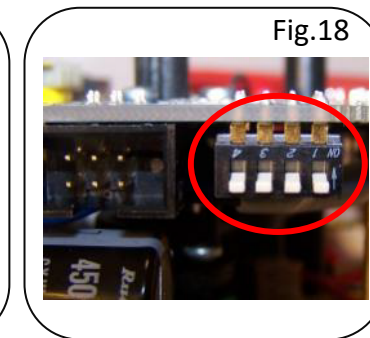
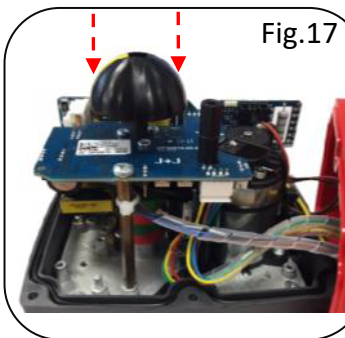
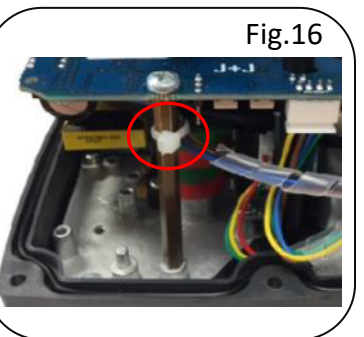
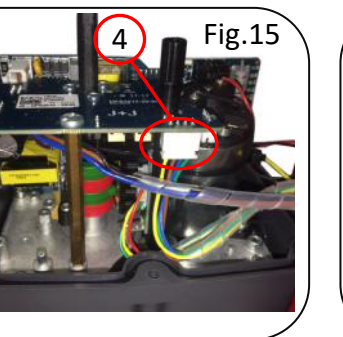
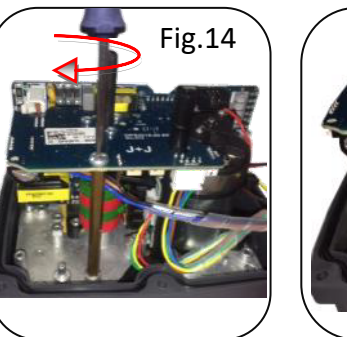
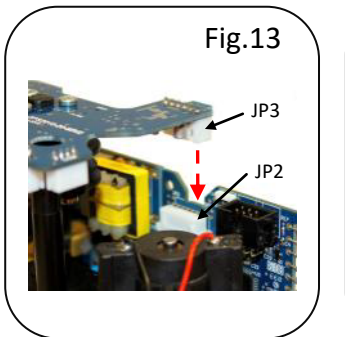
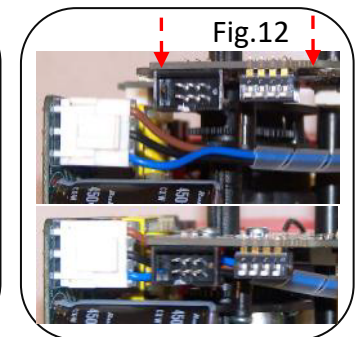
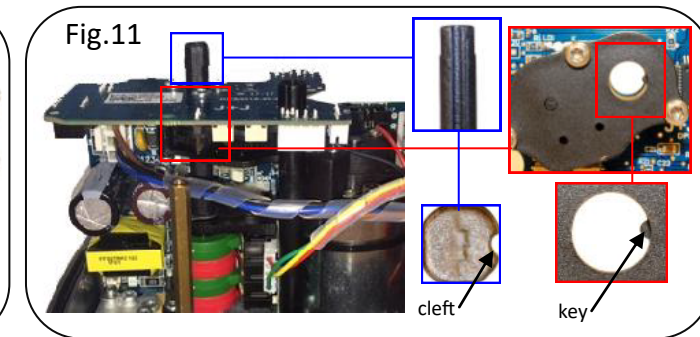
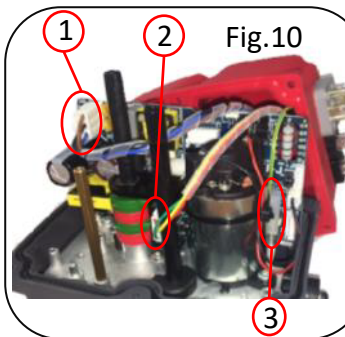
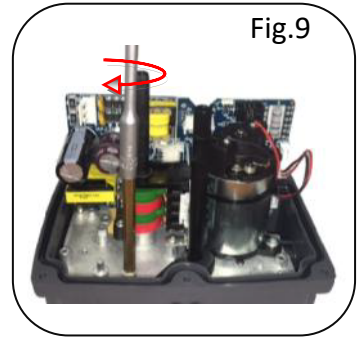
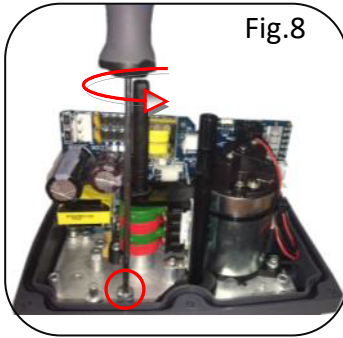
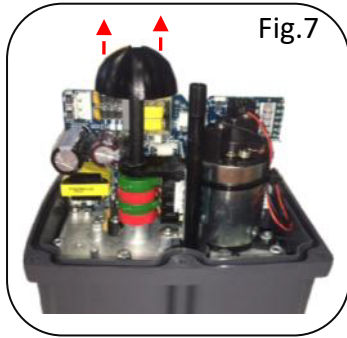
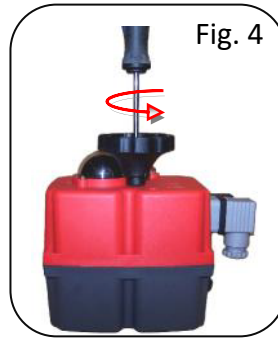
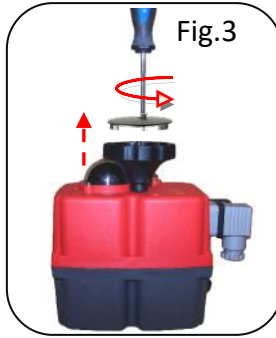
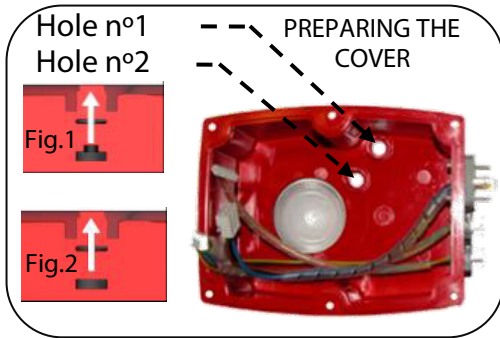

DPS 2017 J 3 C S 20/85

Autoajuste externo DPS 2017/ DPS 2017 External Self-adjustment

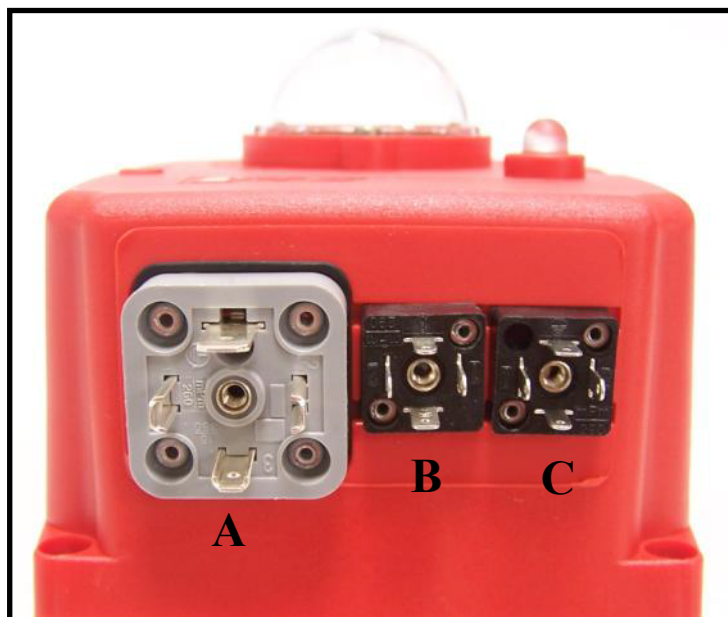

- A-** Conector alimentación corriente (Voltaje).
- B-** Conector alimentación instrumentación (4/20mA,0/10V,0/20mA o 1/10V).
- C-** Conector señales confirmación (libres de tensión).

- 1-En el conector B, hacer un cruce entre el PIN1 (PIN izquierda) y el PIN TIERRA (PIN inferior).
 - 2-En el conector A, conectar el voltaje al actuador de la siguiente manera.
VAC: PIN1 (neutro) y PIN2 (fase).
VDC: PIN1 (negativo) y PIN2 (positivo).
- *IMPORTANTE: ANTES DE CONECTAR EL CONECTOR "A" AL ACTUADOR, REVISAR QUE EL VOLTAJE COINCIDA CON EL DE LA ETIQUETA PEGADA AL ACTUADOR (PARTE COLOR GRIS).**
- 3-En el conector B, deshacer el cruce entre el PIN1 (PIN izquierda) y el PIN TIERRA (PIN inferior).

El actuador realizara una maniobra completa y se quedara en la posición de cerrado.
El actuador ya está listo para conectar la señal de instrumentación en el conector B.

- A-** Power supply plug.
- B-** Input / Output signal (4/20mA,0/10V,0/20mA o 1/10V) plug.
- C-** Volt free contact plug.

- 1-B plug - connect a cable between PIN 1 (on the left side) and PIN Earth (on the bottom).
 - 2-A plug - connect:
VAC: PIN1 (neutral) and PIN2 (phase).
VDC: PIN1 (negative) and PIN2 (positive).
- *VERY IMPORTANT: BEFORE CONNECTING "A" PLUG TO THE ACTUATOR, CHECK THAT THE VOLTAGE IS THE SAME AS THE ONE SPECIFIED ON THE LABEL (CARTER).**
- 3-B plug - disconnect the cable between PIN 1 (on the left side) and PIN Earth (on the bottom).

The actuator will make a complete maneuver and stay in the close position.
The actuator is ready to connect the (4/20mA,0/10V,0/20mA o 1/10V) signal to the B plug.

KIT BSR 2017 J3CS 20/85



OUTSIDE BOX



INSIDE BOX

El sistema de seguridad BSR 2017 es un automatismo que, incorporado a los actuadores J3CS permite, en caso de interrupción de la alimentación eléctrica, situar la válvula en posición preferente predeterminada NC o NA.

En el interior del actuador se encuentra situada la tarjeta del circuito BSR 2017 más el bloque de baterías que, se encuentra en carga continua, lo que permite accionar el actuador, en caso necesario, cuando la unidad detecta un fallo de suministro eléctrico.

Hay que tener en cuenta que no se trata de un actuador "simple efecto", pero que en caso de que la válvula se encuentre en posición no preferente, el sistema BSR 2017, mediante las baterías, accionará la válvula hasta situarla en la posición predeterminada como preferente, actuando como un actuador "simple efecto".

The BSR 2017 safety block system is an automatism that, when coupled to the J3CS multi voltage electric actuators, lets the valve situate in a preferable position NC or NO, when there is a power supply failure. Inside of the housing there are a BSR 2017 print circuit board and a battery pack, which is kept in continuous charge.

In case of the valve is not in the preferable position and there is a power supply cut, the BSR 2017 system returns the valve back to the preferable position by means of the batteries tension, operating as a "single acting" actuator.

KIT BSR 2017 J 3 CS 20/85



OUTSIDE BOX



INSIDE BOX

ESPECIFICACIONES / SPECIFICATIONS

MODELO ACTUADOR / ACTUATOR MODEL	S20-B20	S35-B35	S55-B55	S85-B85
Nº de Maniobras sin recargar, con batería 100% de carga Nº Working operation without recharge, with 100% battery charge	5	5	5	5
Tiempo de recarga/ maniobra. Recharge time/working operation	15 min	21 min	48 min	58 min
Consumo de batería/maniobra. Battery consumption/working operation	2,2 W	3,0 W	6,8 W	8,3 W
Tiempo de carga completa 100% Full charge time 100%	28 h	28 h	28 h	28 h
Capacidad nominal +/- 5% Nominal capacity +/- 5%	1000 mA	1000 mA	1000 mA	1000 mA
Configuración NA o NC (*) NO or NC Features (*)	Jumper	Jumper	Jumper	Jumper
Consumo/una maniobra con batería Current/one working operation with battery	10,1 mA	14 mA	31,6 mA	38.6 mA
Carga batería Battery charge	40 mA/h	40 mA/h	40 mA/h	40 mA/h
Peso Weight	0,27 Kg	0,27 Kg	0,27 Kg	0,27 Kg

J 3 C S 20/85 KIT BSR 2017 ASSEMBLY INSTRUCTIONS

VERY IMPORTANT:

PLEASE, FOLLOW THESE INSTRUCTIONS STEP BY STEP. IF THE CONNECTOR OF THE BATTERY PACK IS PLUGGED TO THE "BSR" PCB, BEFORE ARRIVING TO POINT 9, THE PCB COULD BE DAMAGED.



DOCUMENT TO FILL IN



ASSEMBLY INSTRUCTIONS



INNER BOX

KIT COMPONENT

- A 1 BSR PCB
- B 1 BSR PCB Fixing screw
- C 1 Battery
- D 1 Plastic washer
- E 1 Battery Fixing screw
- F 1 Washer

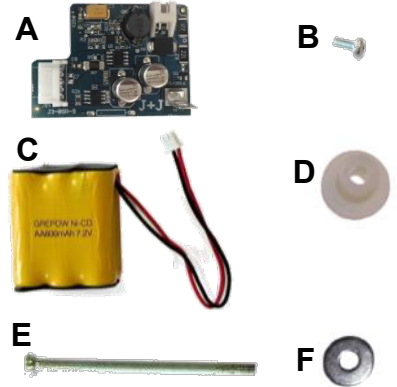

BSR PCB set-up:

Please see the attached label:



Option 1: If **BSR 2015**, is on the label , remove the jumper and follow point 1.

Optionn 2: If **BSR 2017** is on the label, check the jumper is connected and follow point 1.



remove jumper



connected jumper

1. Remove the cover of the hand wheel .
2. Remove the hand wheel screws and take the hand wheel off. (Fig. 1 & 2).
3. Remove the 6 screws between the cover and the body of the actuator.(Fig.3).
4. Carefully remove the cover, in order to install the kit. (Fig.4).
5. Remove the screw indicated in (Fig.5).
6. Place the battery pack (C) on the indicated position (Fig.6).
7. Take the screw kit (E), put the plastic washer (D), put the washer (F) along the screw and introduce it in the battery (Fig.7).
Fix the battery to the base plate.
8. Take the "BSR" PCB (A) from the KIT and connect it to the actuator PCB, by using the connectors marked with a circle. See (Fig.8).
9. Fix the "BSR" PCB to the base plate by using the screw (B). See (Fig.9).
10. Plug the battery pack connector to the "BSR" PCB base connector, located on the top of this PCB (Fig.10).
11. BSR Configuration (Fig.11 jumper SELDIR): NC (normally close) jumper ON.
NO (normally open) jumper OFF.
12. Carefully replace the cover and be sure that the joint is correctly lodged in its place. See (Fig.12).
Be sure that any cable is not trapped between the cover and the body.
13. Fix the 6 screws, between the cover and the body. See (Fig.13).
14. Reassemble the hand wheel and fix it with the screws. See (Fig.14).
15. Put the hand wheel cover back and fix it with the screw. See (Fig.15).
16. Fill in the blanks of the document inside the BSR KIT and send it back to the supplier, via fax or mail.

Now, the actuator is ready to work.

We strongly recommend to put the power on, send the actuator to an intermediate position and check that, after putting the power off, the actuator goes to the pervious set-up position (NC or NO).

